

**MODEL:** UP32-C-F-G-FL-2-P24-TR | **DESCRIPTION:** USB PLUG**FEATURES**

- USB Type C plug
- USB 3.2 Gen 1
- 5 Gbits/s data transfer speed
- reflow solder compatible
- tape & reel packaging

**SPECIFICATIONS**

| parameter                       | conditions/description  | min | typ    | max                 | units       |
|---------------------------------|---|-----|--------|---------------------|-------------|
| USB standard                    | USB 3.2 Gen 1   |     |        |                     |             |
| rated input voltage             |   |     |        | 30                  | Vdc         |
| rated input current             | as per EIA-364-70, Method B<br>power pins collectively [A1, A4, A9, A12, B1, B4, B9, B12]<br>VCONN pins individually [A5, B5]<br>all other signal pins individually |     |        | 5.0<br>1.25<br>0.25 | A<br>A<br>A |
| contact resistance <sup>1</sup> | between terminals and mating plug   |     |        | 40                  | mΩ          |
| insulation resistance           | at 100 Vdc between adjacent contacts  | 100 |        |                     | MΩ          |
| voltage withstand               | between adjacent contacts for 1 minute  | 100 |        |                     | Vac         |
| insertion force                 | at a rate of 30 cycles/min  | 5   |        | 20                  | N           |
| withdrawal force                | at a rate of 30 cycles/min  | 8   |        | 20                  | N           |
| life                            | at a rate of 500 cycles per hour  |     | 10,000 |                     | cycles      |
| operating temperature           |   | -25 |        | 85                  | °C          |
| flammability rating             | UL94V-0   |     |        |                     |             |
| RoHS                            | yes   |     |        |                     |             |

Note: 1. When measured at 20 mV / 100 mA.

**SOLDERABILITY**

| parameter        | conditions/description      | min | typ | max | units |
|------------------|-----------------------------|-----|-----|-----|-------|
| reel storage     | at 20~30°C, 40~75% humidity |     |     |     |       |
| reflow soldering | see reflow profile          |     |     | 260 | °C    |

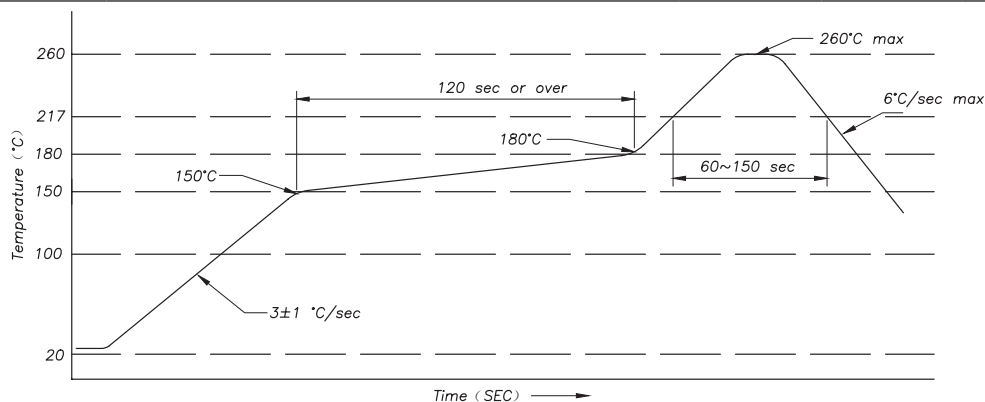

## MECHANICAL DRAWING

units: mm  
 tolerance:  
 X.X ±0.30 mm  
 X.XX ±0.20 mm  
 X.XXX ±0.10 mm  
 unless otherwise specified

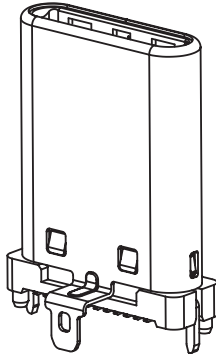

| DESCRIPTION | MATERIAL      | PLATING/COLOR  |
|-------------|---------------|--|
| housing     | LCP (UL94V-0) | black  |
| contact     | C7035         | contact area: 3 μ" gold<br>over 50 μ" nickel<br>solder area: 80 μ" tin |
| latch       | SUS301        | solder area: 80 μ" tin<br>over 50 μ" nickel                            |
| spring      | SUS304        | clear  |
| front shell | SUS304        | 30 μ" nickel   |

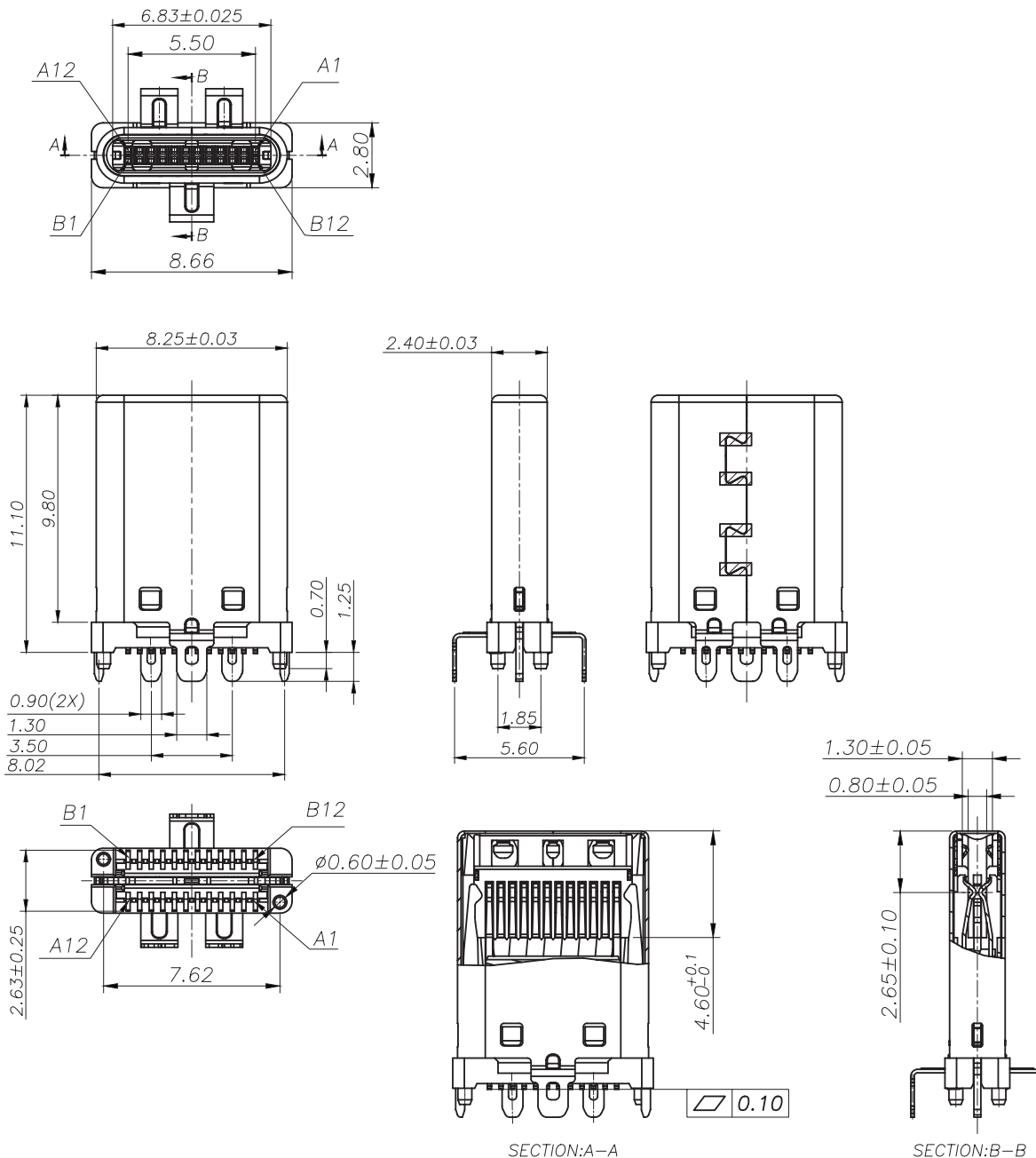

SECTION:A-A

SECTION:B-B

## MECHANICAL DRAWING (CONTINUED)

units: mm  
 PCB tolerance:  $\pm 0.05$  mm  
 PCB thickness:  $0.8 \pm 0.10$  mm

| PIN CONNECTIONS |             |     |             |
|-----------------|-------------|-----|-------------|
| PIN             | SIGNAL NAME | PIN | SIGNAL NAME |
| A1              | GND         | B12 | GND         |
| A2              | SSTXp1      | B11 | SSRXp1      |
| A3              | SSTXn1      | B10 | SSRXn1      |
| A4              | VBUS        | B9  | VBUS        |
| A5              | CC1         | B8  | SBU2        |
| A6              | Dp1         | B7  | Dn2         |
| A7              | Dn1         | B6  | Dp2         |
| A8              | SBU1        | B5  | CC2         |
| A9              | VBUS        | B4  | VBUS        |
| A10             | SSRXn2      | B3  | SSTXn2      |
| A11             | SSRXp2      | B2  | SSTXp2      |
| A12             | GND         | B1  | GND         |

with cover:

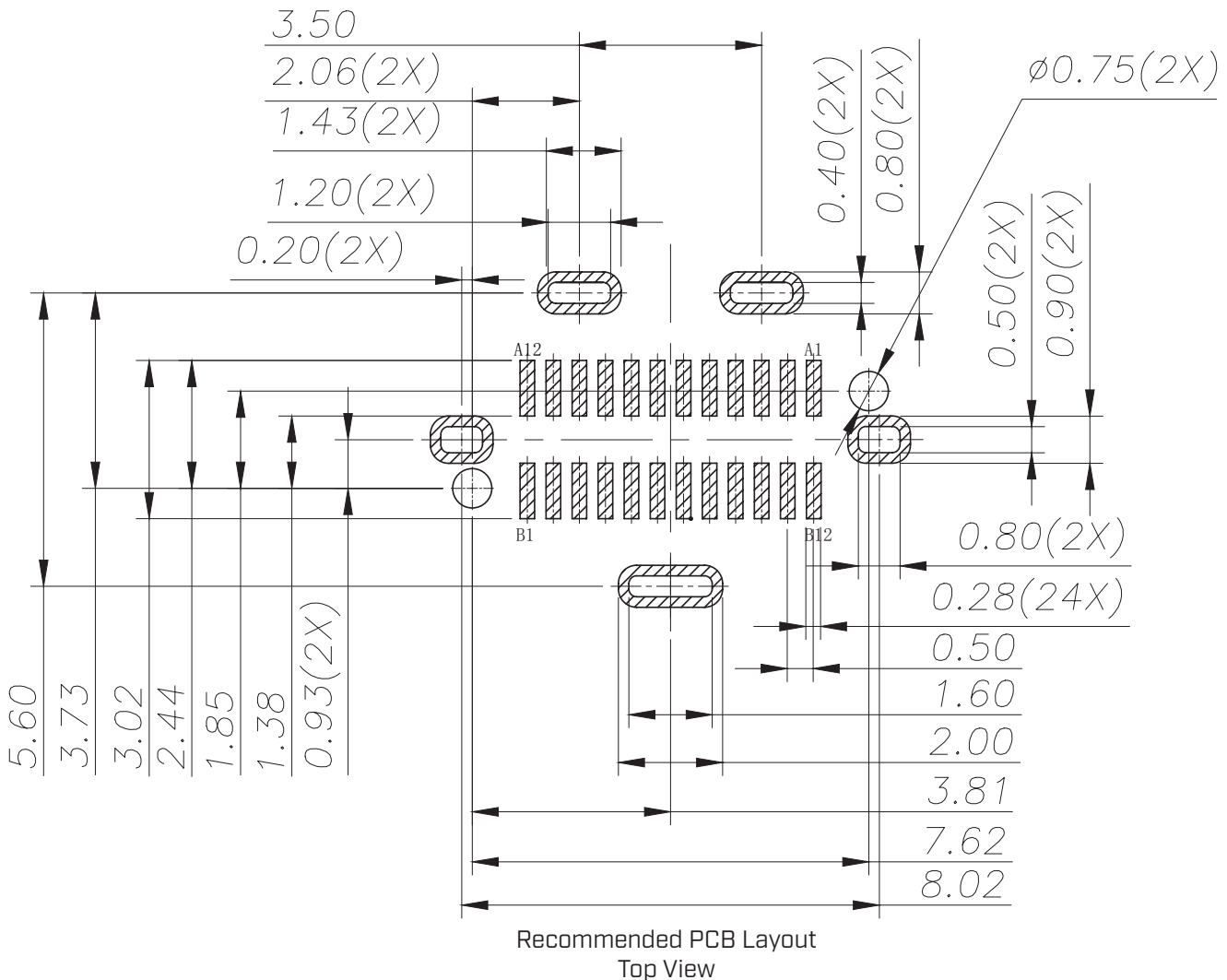
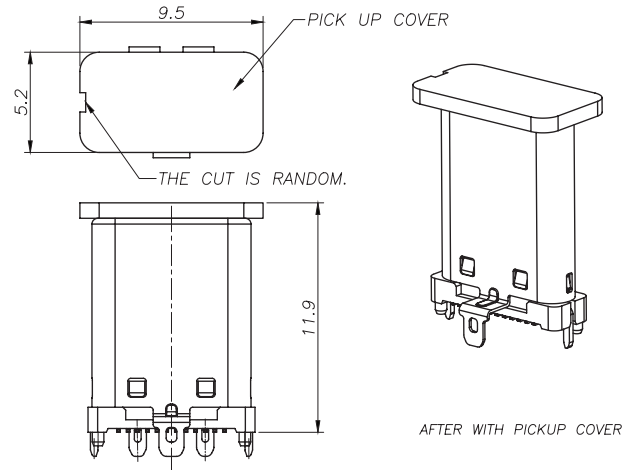

## PACKAGING

units: mm

Reel Size:  $\varnothing 380$   
 Reel QTY: 400 pcs per reel  
 Carton Size: 330 x 330 x 320 mm  
 Carton QTY: 4,000 pcs

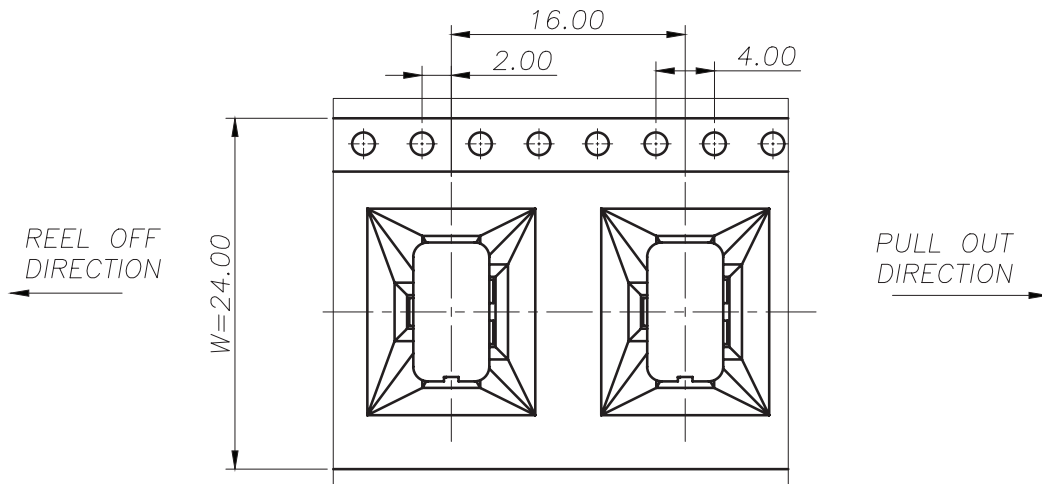
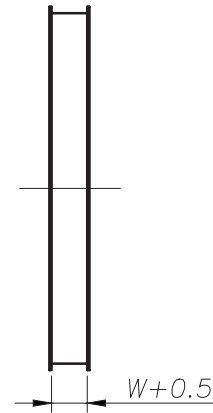
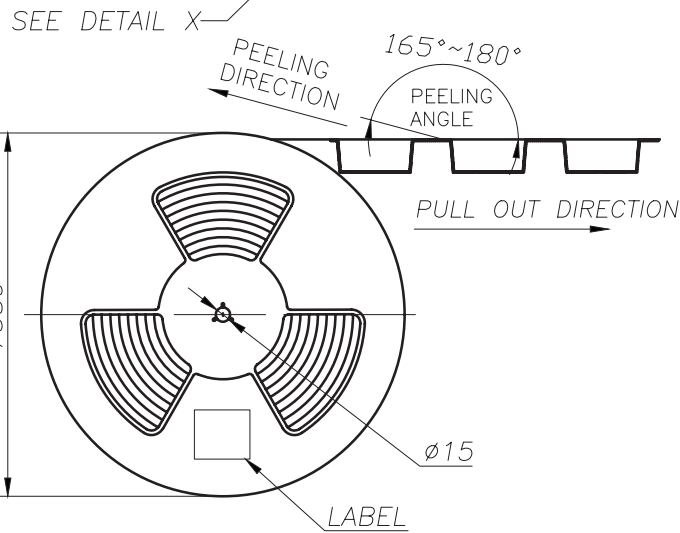
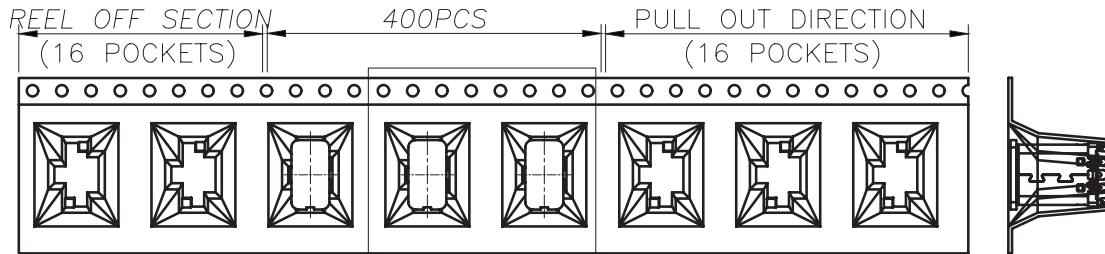

DETAIL X  
 SCALE 2:1

## REVISION HISTORY

| rev. | description     | date       |
|------|-----------------|------------|
| 1.0  | initial release | 07/31/2024 |

The revision history provided is for informational purposes only and is believed to be accurate.



CUI Devices offers a one (1) year limited warranty. Complete warranty information is listed on our website.

CUI Devices reserves the right to make changes to the product at any time without notice. Information provided by CUI Devices is believed to be accurate and reliable. However, no responsibility is assumed by CUI Devices for its use, nor for any infringements of patents or other rights of third parties which may result from its use.

CUI Devices products are not authorized or warranted for use as critical components in equipment that requires an extremely high level of reliability. A critical component is any component of a life support device or system whose failure to perform can be reasonably expected to cause the failure of the life support device or system, or to affect its safety or effectiveness.

[cuidevices.com](http://cuidevices.com)