

## Product Change Notice (PCN)

**Date:** 07/25/2024

**PCN Number:** PCN-0531141R-01

To Our Customers:

We appreciate your use of our products. Our commitment in maintaining and improving processes is demonstrated by plans to enhance our product quality, reliability, and manufacturability. The purpose of this notice is to inform you of a product change.

Product(s) Affected: *CBL-UC-UC-05BP, CBL-UC-UC-05BT, CBL-UC-UC-05WP, CBL-UC-UC-05WT, CBL-UC-UC-05GP, CBL-UC-UC-05GT, CBL-UC-UC-10BP, CBL-UC-UC-10BT, CBL-UC-UC-10WP, CBL-UC-UC-10WT, CBL-UC-UC-10GP, CBL-UC-UC-10GT, CBL-UC-UC-15BP, CBL-UC-UC-15BT, CBL-UC-UC-15WP, CBL-UC-UC-15WT, CBL-UC-UC-15GP, CBL-UC-UC-15GT, CBL-UC-UC-20BP, CBL-UC-UC-20BT, CBL-UC-UC-20WP, CBL-UC-UC-20WT, CBL-UC-UC-20GP, CBL-UC-UC-20GT*

All USB 2.0 Type C to C Cables.

Reason(s) for Change: *Modified Design. VDC listing update.*

Description of Change: *B5 (VCONN) power output control protocol line was removed from the design. VDC listing needs to be changes from 30 vdc to 5 vdc.*

Before:

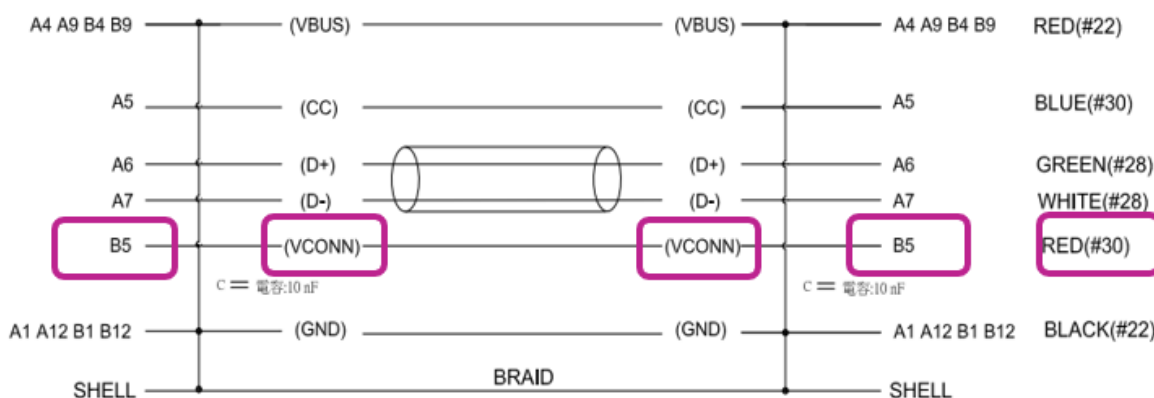

After

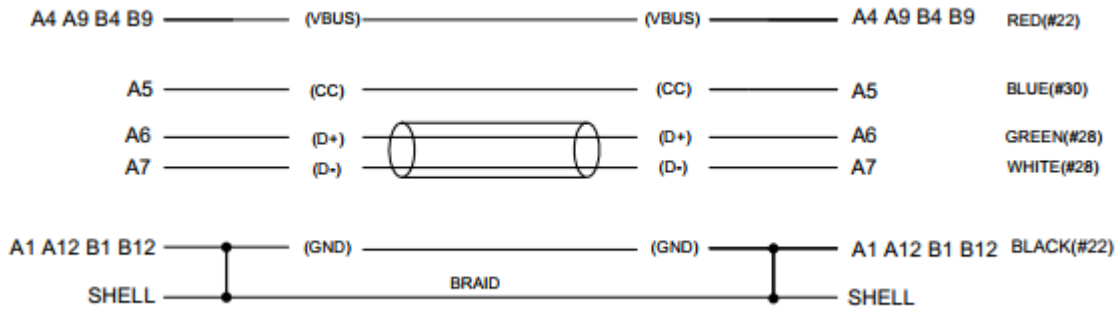

Affected Date Code: *0524*

Product Availability: *Existing inventory is being replaced with new material. Any production orders marked 0524 or later will have the new design implemented.*

PCN Approval:

Operations/Quality



Product Management

